

**DC INTEGRATED FLYWHEEL STARTER GENERATOR MOTORS
FOR 24 V HYBRID DRIVE SYSTEMS**

**2 kW
Starter motor**

**5 kW
Generator**

**5 kW
Electric motor
propulsion**

**10 kW
short time Electric
motor "booster"**



Convenient electric system for:

- Boats
- Stationary generator sets
- Special vehicles

The integrated starter generator is an advanced electrical machine controlled by electronics and is intended for integration with internal combustion engines. It replaces the conventional starter motor and alternator, which are the two indispensable electric units on almost every engine.

This new integrated starter generator offers several new functions so the final users get the following operation modes from a single integrated starter generator:

- **Starter mode** for the main internal combustion engine
- **DC generator mode** for battery charging replacing the alternator
- **Electric motor mode** for electric propulsion
- **Booster electric motor mode** as an extra power to the IC engine for better acceleration

Engines equipped with this device will become especially attractive for operation on **boats, special vehicles and stationary generator sets.**

By assembly of this integrated starter generator through the mechanical couplings on main engine side as well as on the gearbox side, the drive system becomes of a hybrid kind that can expand its use into restrictive areas and in general offers a bigger comfort for the final users.

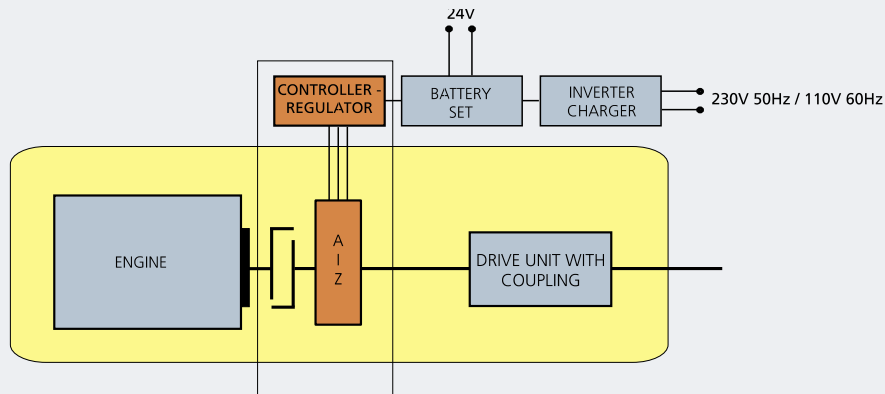

LAY OUT SAMPLE OF MARINE HYBRIDE PROPULSION SYSTEM

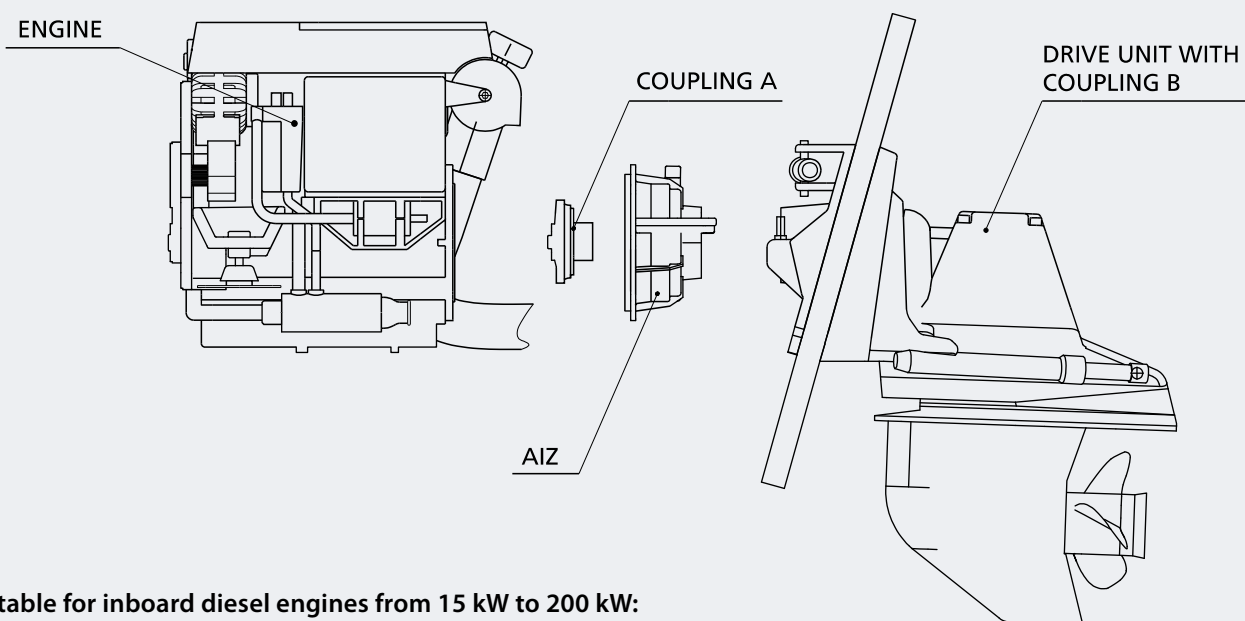

Suitable for inboard diesel engines from 15 kW to 200 kW:

- Sail drives
- Stern drives
- Inboard with shaft drive

MODES OF OPERATION

All functions and operating modes are engaged and controlled with the electronic controller through input pins or CAN bus communications.

A. Starting mode

Coupling A must be engaged and coupling B disengaged for this mode of operation. The integrated starter generator will efficiently rotate the engine with cranking speed and by this provide about 2 kW power to start the engine. Direction of rotation can be adjusted to the rotation of IC engine. Upon release of the start function, the system will automatically switch to generator mode.

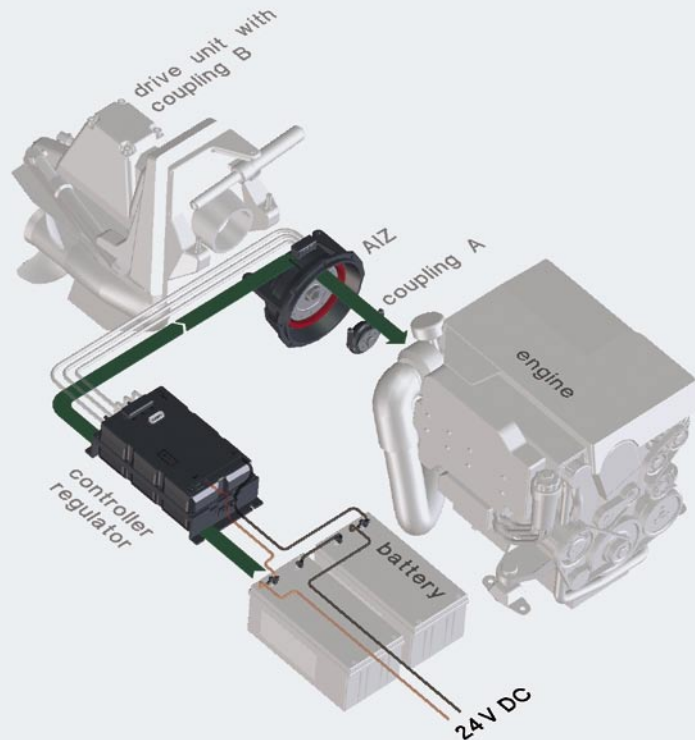

B. Generator mode

Coupling A must be engaged during this mode. Generator mode is engaged immediately after a start or a boost function has ended. Generator will provide 5kW of continuous DC electric power through the electronic controller to the batteries and all the loads on the batteries.

The charging voltage can be selected by pin condition on input connector and it can be accommodated to wet or gel cells with nominal voltage of 24V.

Available is the option to connect standard inverters in parallel to the 24V batteries with 230V 50Hz or 110 V 60 Hz AC output in those applications that have loads intended for AC electricity like many domestic appliances. Obviously final users will enjoy such inverter operation when the main engine is running for longer periods of time or when stopped for a limited time depending on battery capacity.

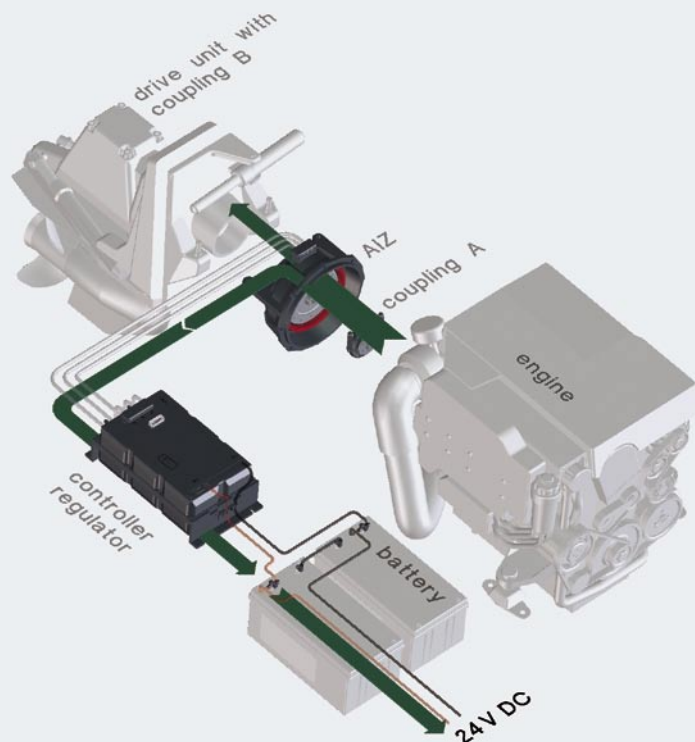

C. Electric propulsion mode

Coupling **A** must be disengaged and coupling **B** must be engaged in order to engage this mode of operation. Main IC engine will be stopped during this mode and therefore the user will enjoy a very quiet drive.

The integrated **starter generator motor** will provide 5kW of output power as electrical propulsion for a limited time dependent on batteries capacity. With a 24V 200Ah fully charged battery set it is expected the system could operate for about half an hour.

Speed of rotation can be controlled by means of connecting a joystick-potentiometer to the pins on input connector or can be commanded through the CAN buss.

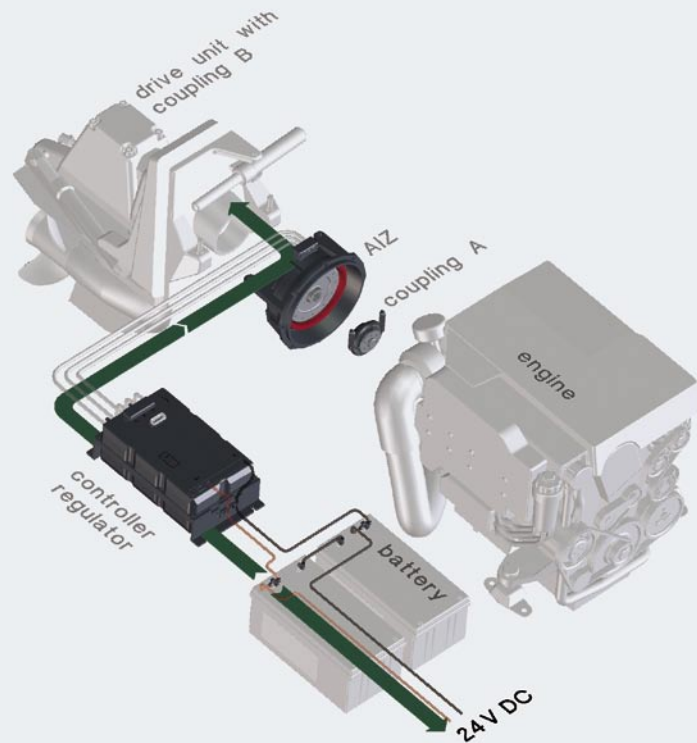

D. Booster mode

During this mode both couplings **A** and **B** need to be engaged.

The integrated starter generator operates in this mode as an electric motor in parallel with the main combustion engine therefore contributing about 10kW extra power in addition to main engine power. The boost effect is more perceivable at low speeds of the main engine and will practically become negligible for speeds over 2500 rpm.

Booster mode is limited to 15 seconds of operating time by software in the controller in order to prevent overheating of system components. Several boost cycles can be engaged subsequently it being overheat protection will cut off this function. At this point the system will need to cool down before a new cycle can be engaged again.

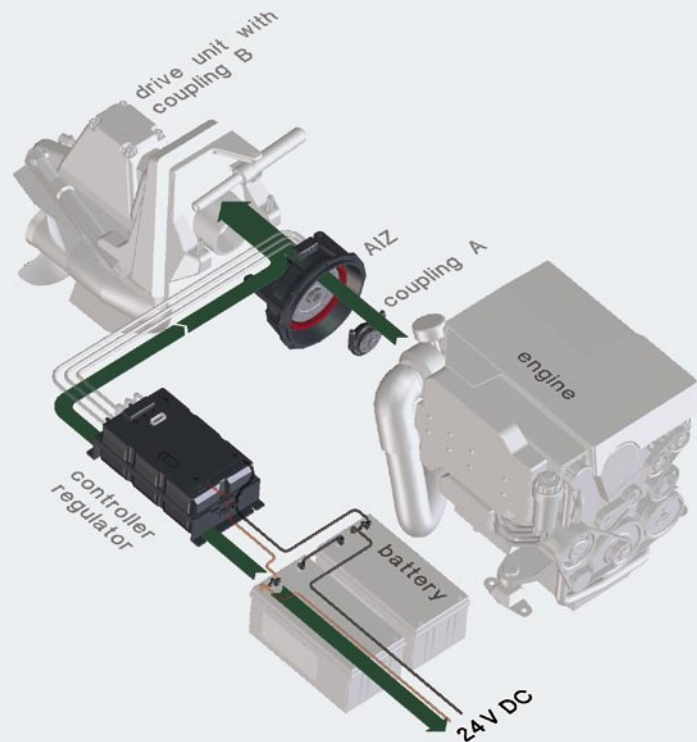



Features of flywheel starter - generator - motor

- Four operating modes (starter, generator, electric propulsion and booster)
- Maintenance free brushless solution
- High efficiency
- High specific power
- 28 V DC output
- Over current and over temperature protection
- Silent operation
- Compact design of electric motor which is integrated in the flywheel housing
- Eliminates the conventional alternator and starter motor
- Reduces outline dimensions of the engine
- Provides selectable charging voltage for wet or gel batteries
- No contactors are requested in electrical connections

The system substitutes some conventional elements of the engine. These are alternator, starter motor and fly wheel elements. Usually assembly leads to a little prolongation of the engine but its width becomes narrower. The stator with windings needs to be installed in a modified flywheel housing which must include the cooling tubes for the coolant. The necessary modifications on the engine flywheel housing and the coupling to the rotor must be carefully redesigned in collaboration with both sides engineering.

DESIGN

Iskra's integrated starter generator is a three-phase brushless permanent magnet synchronous machine controlled by power electronics. The system consist of stator, rotor and a separate electronic controller which enables control over four different operational modes namely with functions of starter, generator, electric propulsion and booster.

Stator

The stator has a three-phase winding on a laminated pack. The optimised design and high fill factor of the winding provide improved efficiency, low noise operation and high output characteristics of the system. For nominal output power, adequate water-cooling must be provided through the flywheel housing cooling tubes.

Rotor

The rotor integrates high-energy rare earth permanent magnets and without any windings or electrical slip rings assures long life and maintenance free operation. It is normally fixed to the engine flywheel with 12 screws. Such assembly needs to be well mechanically balanced.

Electronic controller - regulator

The electronic controller is located in a separate box and integrates small signal electronics and power elements of the most advanced IGBT technology. In the small signal part of the electronics are flash microcontrollers which efficiently control the electric machine and at the same time provide remote control either through the pins on input connector or through the CAN buss connector.

The power stage is assembled on a base plate in which the sea water resistant cooling tubes provide necessary heat dissipation. For convenience during electric installation the electronic controller box already carries a fuse, which is normally in + line with the batteries.

MAIN TECHICAL DATA

Nominal voltage	24 V
Starter output power	2 kW
Maximal torque	180 Nm
DC generator output power	5 kW continuous
Generator voltage	28.1 or 28.8 V
Max output current	200 Amps
Electric propulsion output power	5 kW at 1000 RPM 30 minutes
Booster output power	Up to 10 Kw for 15 seconds
Stator weight	8 kg
Rotor weight	8 kg
Max rotor speed	4500 RPM
Electronic controller weight	22 kg
Electronic controller dimensions	580 x 310 x 205 mm
MAX liquid coolant temperature	30° C
MIN coolant flow	4 litre/min

STARTER GENERATOR AND ELECTRONIC CONTROLLER DIMENSIONS

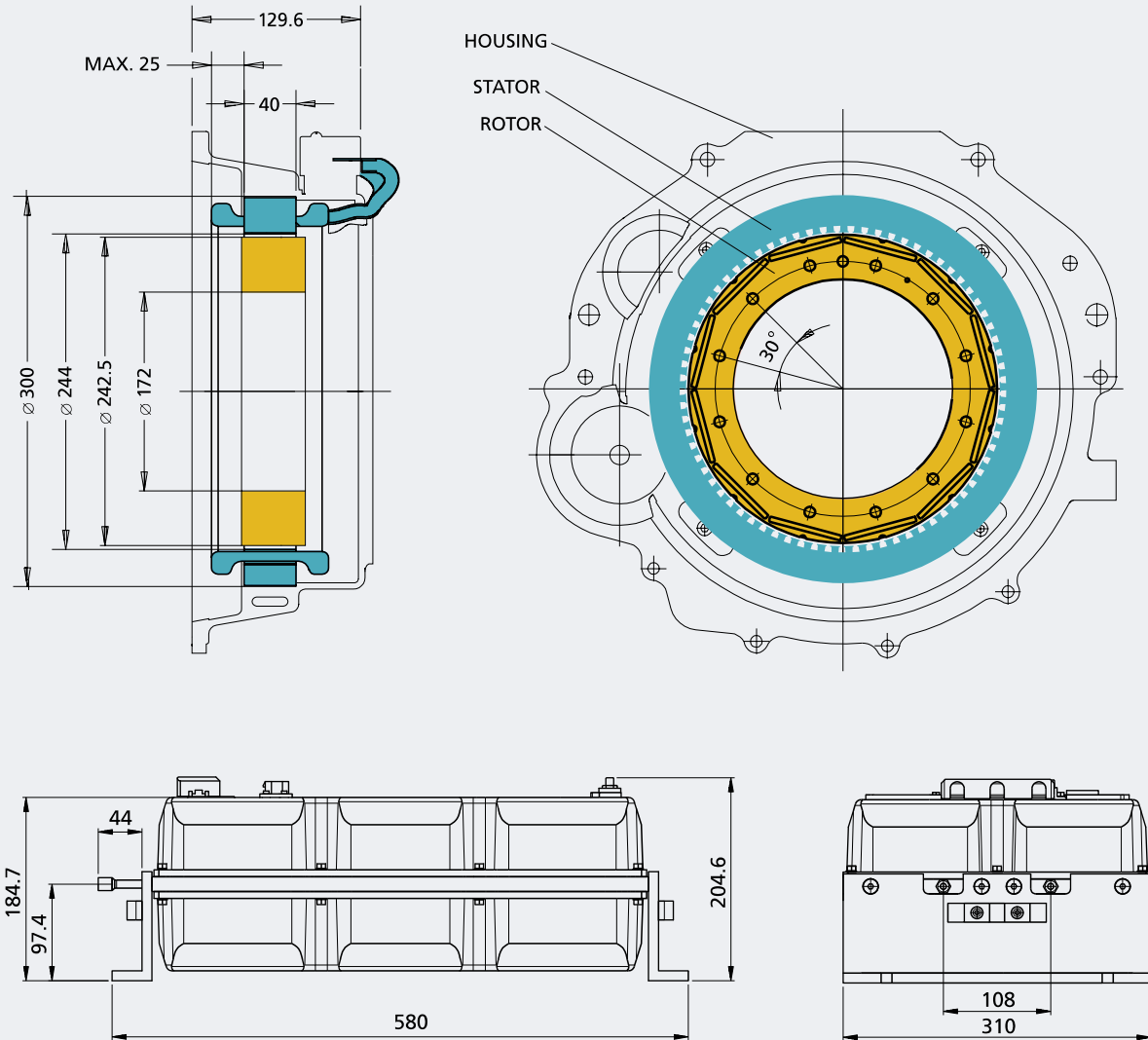

CONNECTION DIAGRAM

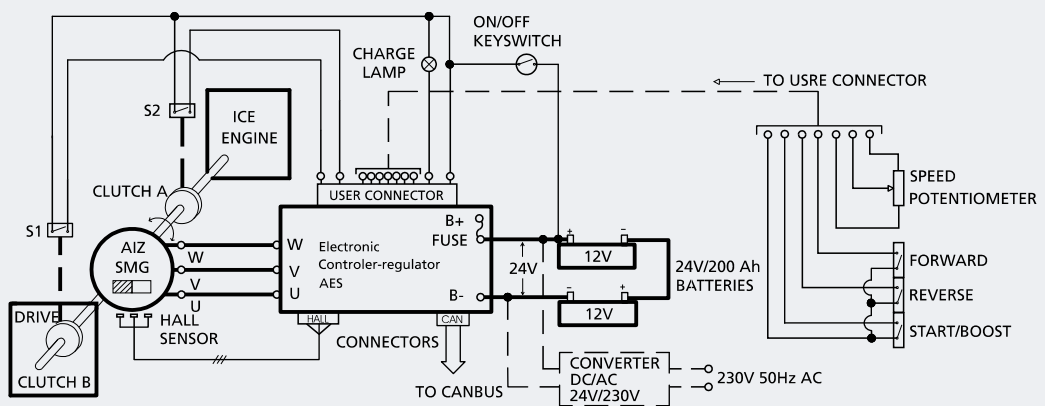

CHARACTERISTICS

A. Starter characteristics

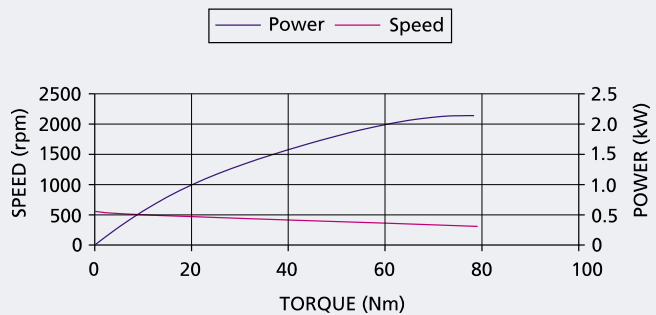

B. Generator characteristics

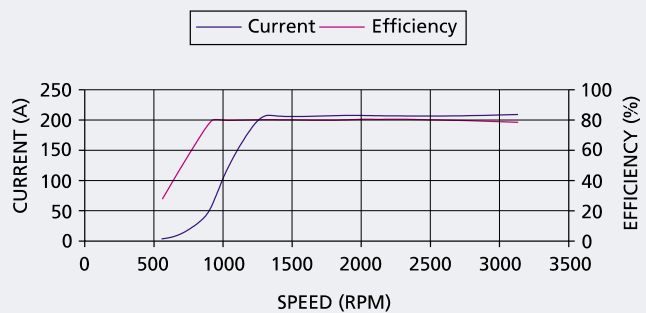

C. Electronic propulsion characteristics

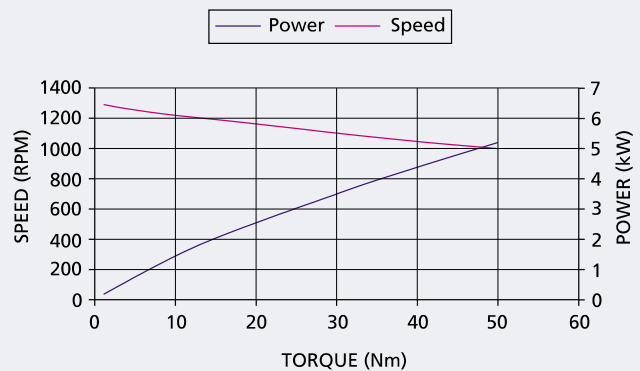

D. Booster characteristics

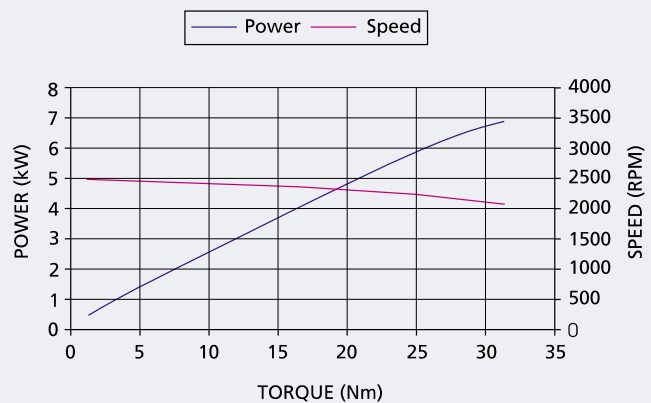

E. Batteries

The batteries represent the fuel tank of the electric motor system. It is very important to choose the batteries that, in size and capacity, suit to your requirements. Please note that you must use batteries that can be discharged by 75 - 80% on regular basis. They can be Wet, Gel or AGM type of lead batteries. DO NOT use starting batteries. They are not developed for deep discharge.

Iskra Avtoelektrika, d. d.

Polje 15, Slovenia, 5290 Šempeter pri Gorici

Tel.: +386 5 33 93 000

Fax: +386 5 33 93 801

E-mail: info@iskra-ae.com

www.iskra-ae.com

DISTRIBUTION NETWORK**BELARUS**

IskRa o. o. o.
Ul. Dombrovskogo 69
230002 Grodno
Tel.: +375 152 487 484
Tel/Fax: +375 152 487 485
E-mail: iskra@mail.grodno.by

BOSNIA AND HERZEGOVINA

Iskra AE Komponente, d. o. o.
Nemanjina 35
78250 Laktaši
Tel.: +387 51 53 07 85
Fax: +387 51 53 53 15
E-mail: iskra-ae@inecco.net

BRAZIL

Iskra do Brasil Ltda.
Rua Testa n. 81 -
Jardim Sao Sebastiao
Jaguariuna - (SP)
CEP 13820-000
Tel.: +55 19 3837 2363
Fax: +55 19 3837 3185
E-mail: uros.kravos@iskra-ae.com
www.iskra-ae.com.br

CHINA

Iskra Suzhou Autoelectric Co., Ltd.
Wenzhou Industrial Zone Shuangfeng
Taicang, Jiangsu Province
Tel: +86 512 8160 6888
Fax: +86 512 8160 7799
E-mail: iskrasuzhou@iskra-ae.com
www.iskra-ae.com.cn

Changchun Fawer
Iskra Automotive Electrical Co., Ltd.
No. 2258 Pudong Road
Changchun Economic
Technology Development Zone
Changchun, Jilin Province
Tel.: +86 431 461 5016
Fax: +86 431 461 5017
E-mail: zhj_fa@faw.com.cn

FRANCE

Iskra Autoelectrique S.A.S.
ZA du Chapeau Rouge
56000 Vannes
Tel.: +33 2 97 45 59 90
Fax: +33 2 97 45 59 99
E-mail: iskra@iskra-sa.fr
www.iskra-ae.fr

GERMANY

Iskra Deutschland GmbH
Danziger Strasse 1
71691 Freiberg am Neckar
Tel.: +49 7141 702 69 0
Fax: +49 7141 702 69 33
E-mail: info@iskra-ae.de
www.iskra-ae.de

GREAT BRITAIN

Iskra UK Ltd.
Redlands
Ullswater Crescent, Coulsdon
Surrey CR5 2HT
Tel.: +44 208 668 7141
Fax: +44 208 668 3108
E-mail: sales@iskra-agency.co.uk
www.iskra-ae.co.uk

IRAN

Iskra Autoelectric Iran JVC
No.28, East Mirdamad Avenue
Tehran 15469-34311
Tel.: +98 21 2 226 237 1 - 4
Fax: +98 21 2 226 237 6
E-mail: info@iskra-iran.com

ITALY

Iskra Autel S. r. l.
Via G. Cantore, 2
34170 Gorizia
Tel.: +39 0481 536 800
Fax: +39 0481 536 810
E-mail: info@iskra-autel.it
www.iskra-autel.it

RUSSIA

Iskra Avtoelektrika
Representative Office
Storozhevaya str., 4,
building 1 office 123
111020 Moscow
Tel.: +7 095 726 93 94
Fax: +7 095 225 84 06
E-mail: info@iskra-ae.ru
www.iskra-ae.ru

Pramo Iskra o.o.o.

Zubcovskoe shosse, 21
172387 Rzhev, Tverskaya obl.
Representative office in Moscow:
Elektrozavodskaya str, 21
107023 Moscow,
Tel./fax +7 495 995-2512
E-mail: iskra@pramo.ru

SPAIN

Iskra Autoelectrique Spain S.A.
Calle Llobatona No. 6-D
08840 Viladecans
Tel.: +34 93 647 40 83
Fax: +34 93 647 40 84
E-mail: iskra@iskra-ae.es

USA

Iskra AE Inc.
4814 American Road
Rockford, IL 61109
Tel.: +1 800 474 1996
Tel.: +1 815 874 4022
Fax: +1 815 874 4024
E-mail: iskra@iskraae.com
www.iskraae.com