

INTEGRATED STARTER MOTOR GENERATORS

T Y P E S

DC INTEGRATED
FLYWHEEL
GENERATORS

AC INTEGRATED
FLYWHEEL
GENERATORS

DC INTEGRATED FLYWHEEL
STARTER MOTOR GENERATORS
FOR HYBRID DRIVES



Iskra

Iskra Avtoelektrika d.d.

DC integrated flywheel generators



AC integrated flywheel generators



DC integrated flywheel starter motor generators
for hybrid drives





INTEGRATED FLYWHEEL STARTER MOTOR GENERATORS ARE DESIGNED IN DIFFERENT VERSIONS TO MEET VARIOUS APPLICATIONS WHERE A HIGH CONSUMPTION OF ELECTRIC ENERGY IS NEEDED AND FOR HYBRID DRIVES. THEY ARE MAINLY USED IN ENGINES FOR BOATS AND INDUSTRIAL APPLICATIONS, VEHICLES WITH SPECIAL ELECTRIC ENERGY NEEDS AND STATIONARY AND PORTABLE POWER SETS. FOLLOWING THE FUNCTIONS THAT THE SYSTEM CAN PERFORM THERE ARE DIFFERENT SOLUTIONS OF INTEGRATED FLYWHEEL STARTER MOTOR GENERATORS OR INTEGRATED FLYWHEEL GENERATORS.

They can occur as:

- **DC integrated flywheel generators**
- **AC integrated flywheel generators**
- **DC integrated flywheel starter motor generators for hybrid drives**

The starter motor generators are designed to be built on the flywheel housing between the engine and the gearbox, which enables new functionality and many features regarding the classic solutions of starter and generator.



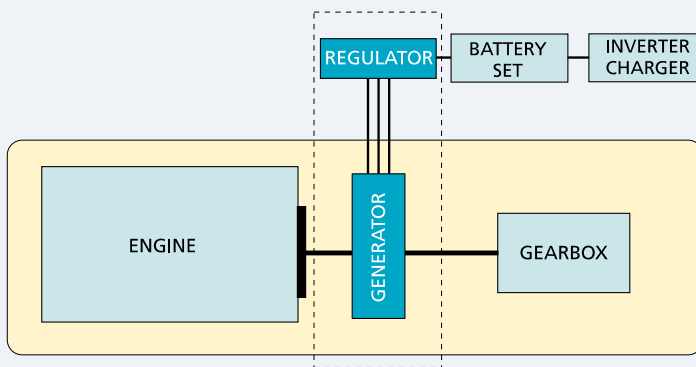

AIZ integrated generator

APPLICATIONS

The integrated flywheel generator is intended for integration in internal combustion engines and for the use in the electric systems, where high consumption of electric energy occurs. The generator is designed to be built on the flywheel housing of the engine between the engine and the gearbox. This design enables many features regarding to the classic electric generator supply systems as it is defined in features in the specifications of the generator. The flywheel generator AIZ is mainly suitable for the applications in electric systems used in:

- Marine applications
- Stationary power sets
- Vehicles for special applications

FEATURES

- High efficiency (> 80 %)
- High specific power
- Possible output voltages: 14V, 28 V and 42 V DC
- Output voltages with an additional inverter: 110 V or 230 V AC
- Maintenance-free solution
- Over-current and temperature protection
- Compact design integrated on the flywheel saves space on the engine
- Engine belt can be eliminated
- Selectable charging voltage (for wet or gel cell)
- Temperature dependent charge

DESIGN

Iskra's integrated generator is a three-phase 12-pole brushless permanent magnet generator. The system includes a stator, a rotor and a separate electronic regulator with a single or two galvanically separated outputs. The outputs provide continuous electric power of up to 4.5 kW of the nominal voltages of 14 V, 28 V and 42 V. For 24 V and 42 V the higher output power is possible. The compact construction and the mode of mounting make it possible to reduce the needed mounting space at high output power. Carefully selected materials assure improved technical characteristics, long life and maintenance free operation even under the harshest conditions.

Stator

The stator has a three-phase winding on a laminated pack. The selected design and high filling factor of the winding provide improved cooling, low noise and high output characteristics of the generator. For nominal output power, adequate water-cooling must be provided through the flywheel housing defined by the customer.

Rotor

The rotor with 12 high-energy rare earth permanent magnets and without slip rings assures long life and maintenance free operation.

Electronic regulator

A separate electronic regulator provides a stable DC output of the nominal voltages of 14 V, 28 V or 42 V. Electric system is not sensitive to sudden and short time overload.

Note: Upon the customer's request for a special design of the electronic controller, additional functions of the system can be provided as for example: engine start, electronic propulsion and acceleration-booster.

MAIN TECHNICAL DATA

| Type | AIZ | |
|---|-----------|----------|
| Nominal voltage | 14 V | 28 V |
| Max current (Two separate outputs) | 2 x 150 A | 2 x 80 A |
| Max current (Two outputs connected in parallel) | 300 A | 160 A |
| Short time output power | 4.2 kW | 4.5 kW |
| Continuous output power | 3.5 kW | 4.5 kW |
| Stator diameter | 300 mm | |
| Stator weight | ~8.5 kg | |
| Rotor weight | ~7.5 kg | |
| Max speed | 5000 rpm | |
| Electronic regulator | Separate | |

GENERATOR AND REGULATOR DIMENSIONS

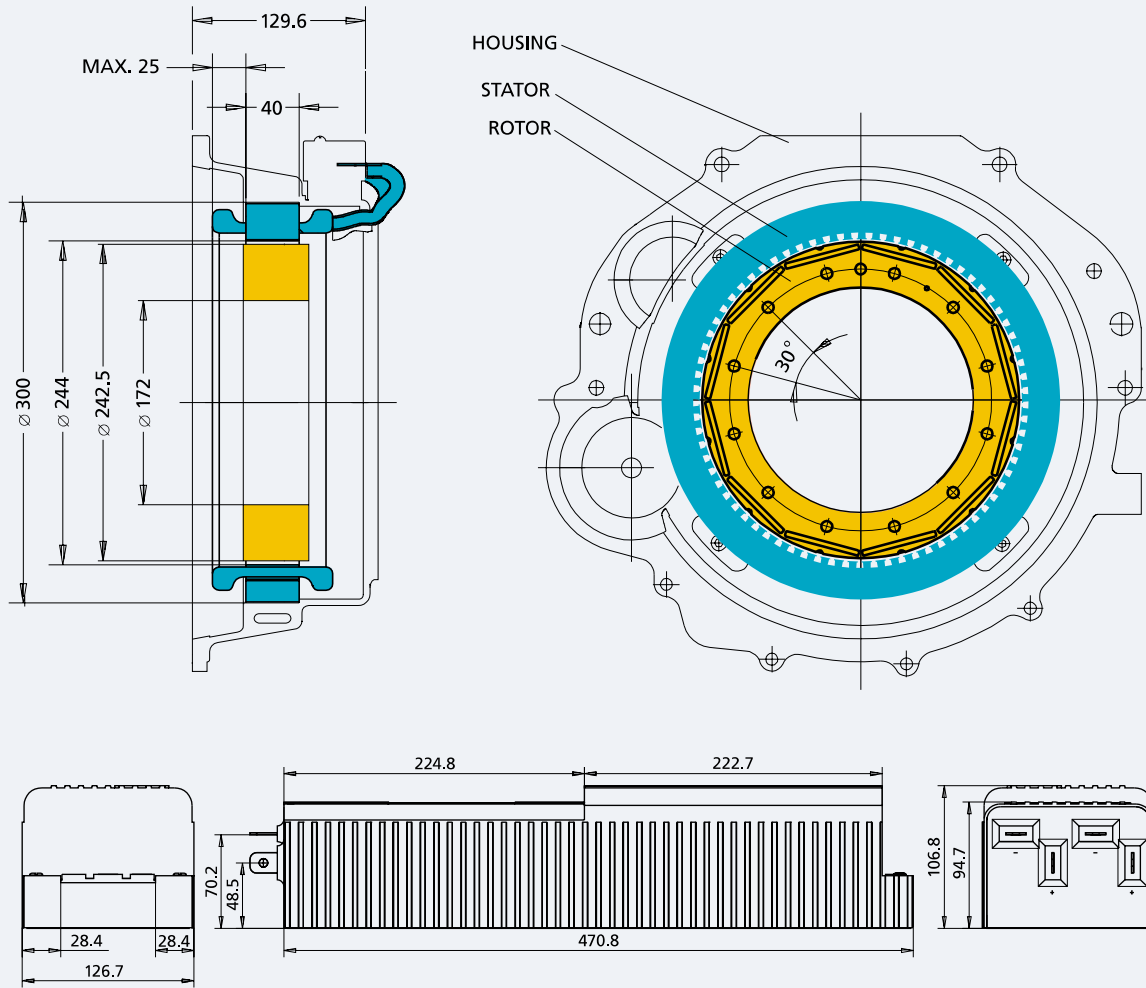

CHARACTERISTIC

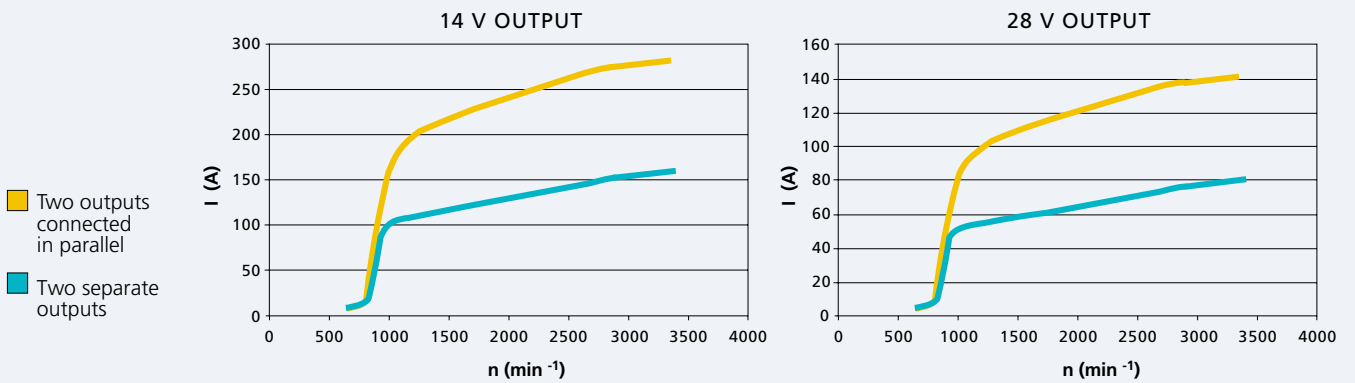

CONNECTION DIAGRAM

NOTE: For installation details see special instructions or contact us.

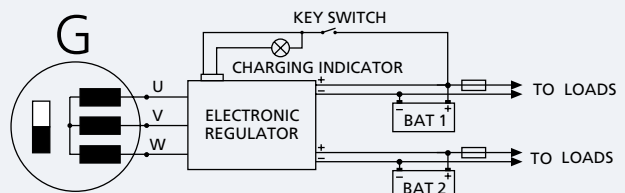

Marine applications

The generators are normally constructed for the nominal voltage 14 V or 28 V, depending on the basic watercraft installation and the maximal output currents 300 A (2 x 150 A) for the 14 V variants or 160 A (2 x 80 A) for the 28 V variants. The appropriate output voltages are achieved by the corresponding regulator. While the internal-combustion engine operates, the generator supplies the watercraft consumers and at the same time enables charging of batteries installed to the watercraft.

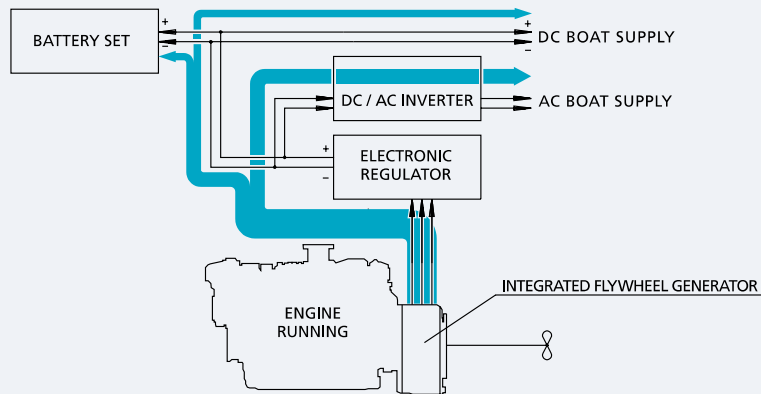

Energy flow during engine operation

In case of engine stand still, it is possible to supply the watercraft consumers, based on the accumulation of electric energy in the batteries.

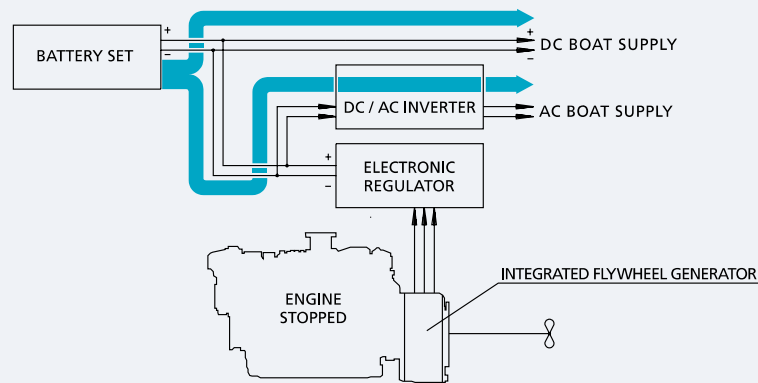

Energy flow during engine is stopped

The minimal number of batteries and their capacity is specified by the requirement for cranking and is regarding the engine capacity and the requirements for cranking, defined by the engine producer. The minimal number of batteries enables limited time of supplying the watercraft consumers. To lengthen this time and to enable bigger consumption it is necessary to install additional batteries.

In cases, where the standard alternating voltage supply of 230 V (or 110 V) is required, this can be realized by the use of the inverters connected to the generator output with batteries that are connected in a parallel manner. This enables a constant supply with the alternating voltage while the generator operates in the appropriate mode. In case of the generator standing still (internal-combustion engine), the supply of the alternating voltage is enabled by the conversion of the in-the-batteries-accumulated energy into the required alternating voltage. The minimal number of batteries enables only short operation. To lengthen the operation and increase the power, additional batteries are necessary.

Different producers have different constructions of inverters. Recommended are the inverters equipped with the appropriate selector switches that enable a switch from the power supply of the watercraft to the standard power supply if this is attainable in the marines. Such inverter also enables charging of batteries at the same time.

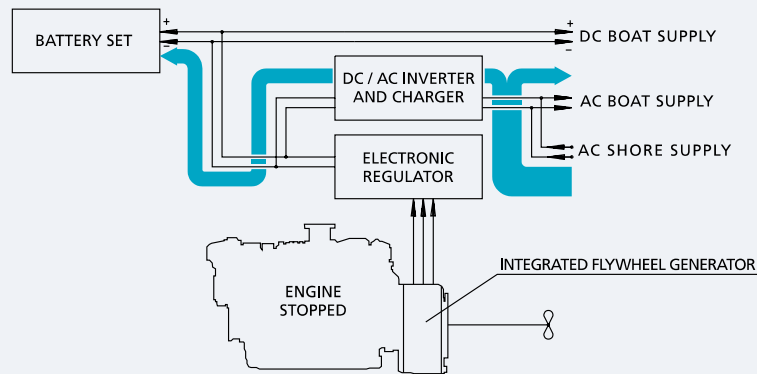

Power supply from the mains in the marines.

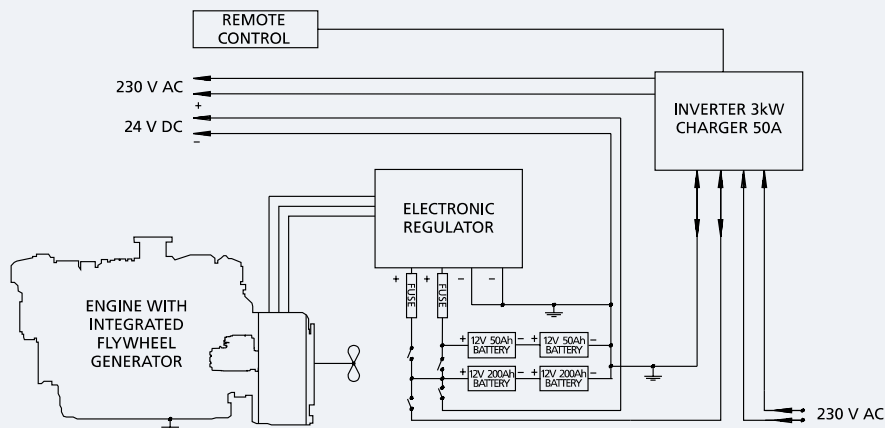

Installation example of integrated flywheel generator into the electric system on the boat

Stationary power sets

AIZ generators are appropriate for incorporation into different types of internal-combustion engines and in this way they make an autonomous power supply unit for different electric systems. Usually they are used as individual units for supplying the consumers of the nominal voltage 12 V and 24 V and charging the battery sets. Together with the inverter and external supply from the mains there are more variants of operation, as defined in the previous chapter of marine applications.

Vehicles

The generators are mainly intended for applications in vehicles, where the supply systems of high energy are required. The generators can be used as the main source of electric energy, where the generators are incorporated to the main engines or as additional power sets as mentioned above. The engine position and the way of application depend mostly on the anticipated electric system of a vehicle, the ways of supply and the type of the consumers in the vehicle.

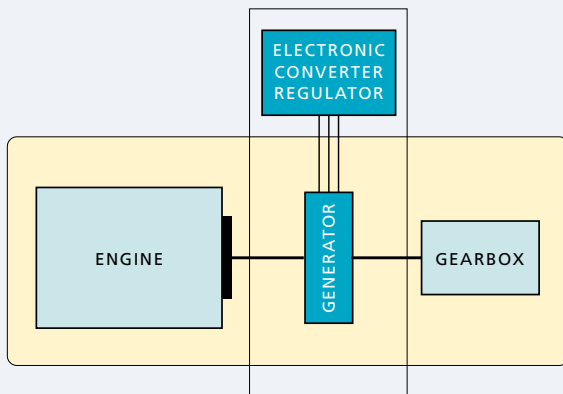

AIZ integrated generator

APPLICATIONS

Iskra 230 V 50 Hz or 110 V 60 Hz AC generators are intended for applications in the systems with high AC electric energy requirements. Generators are primarily designed to be built on the flywheel of the internal combustion engine as compact integrated flywheel generator. For the use in the renewable energy sources through water or wind turbines, the autonomous AC generators can be built. Iskra AC generators are of high quality. They are designed and built according to the customer needs for stationary, portable or mobile applications. Integrated or autonomous AC generators are mainly suitable for:

- Boats and other marine applications
- Special needs on road vehicles
- Special needs on off-road vehicles
- Stationary or portable electric power sets
- As emergency power supply

The generator is designed to be built on the engine between the engine and the gearbox.

FEATURES

- High efficiency (>85%)
- High specific power
- Constant output voltage 230 V 50 Hz or 110 V 60 Hz in wide range of speed of rotation
- Separate electronic converter regulator
- Very stable and low harmonics sine wave voltage on generator output
- Electronics regulator with communication and remote control options
- Maintenance free solution
- Over-current and temperature protection
- Compact design
- EMC compatible

DESIGN

Iskra's integrated 230 V 50 Hz or 110 V 60 Hz generator is based on a three-phase brushless permanent magnet synchronous generator. The system includes a stator, rotor, housing and separate electronic converter regulator enabling a constant output independent of the variable engine speed. The output enables alternative 230 V 50 Hz or 110 V 60 Hz output voltage for power up to 4 kW continuously. The compact construction and the mode of mounting make it possible to reduce the mounting space at high output power. Carefully selected materials assure improved technical characteristics, long life and maintenance free operation even under harshest conditions.

Stator

The stator is a three-phase winding on the laminated pack. Construction and high filling factor of the stator windings provide high power output. For nominal output power, adequate water-cooling must be provided through the flywheel housing defined by the customer.

Rotor

The rotor is designed with high-energy rare earth permanent magnets and no wearing parts, what assures long life and maintenance free operation.

Electronic converter regulator

The separate electronic converter regulator provides a stable 230 V 50 Hz or 110 V 60 Hz output independent of the rotor speed and the electric output loads. Electric system is not sensitive to sudden and short time overloads. This electronic converter regulator has internally controlled air-cooling; therefore no additional cooling installation is required.

MAIN TECHNICAL DATA

| Type | AIZ 230 V 50Hz | AIZ 110 V 60Hz |
|--|-----------------|-----------------|
| Nominal voltage (V) | 230 | 110 |
| Frequency (Hz) | 50 | 60 |
| Short time output power (kW) | 6 | 6 |
| Continuous output power (kW) | 4 | 4 |
| Stator diameter (mm) | 300 | 300 |
| Stator weight (kg) | 8.5 | 8.5 |
| Rotor weight (kg) | 7.5 | 7.5 |
| Max speed (rpm) | 4700 | 4700 |
| Stator cooling | Liquid | Liquid |
| Electronic converter regulator cooling | Air | Air |
| Electronic converter regulator dimensions (mm) | 434 x 319 x 125 | 434 x 319 x 125 |
| Electronic converter regulator weight (kg) | 9.4 | 9.4 |

GENERATOR AND REGULATOR DIMENSIONS

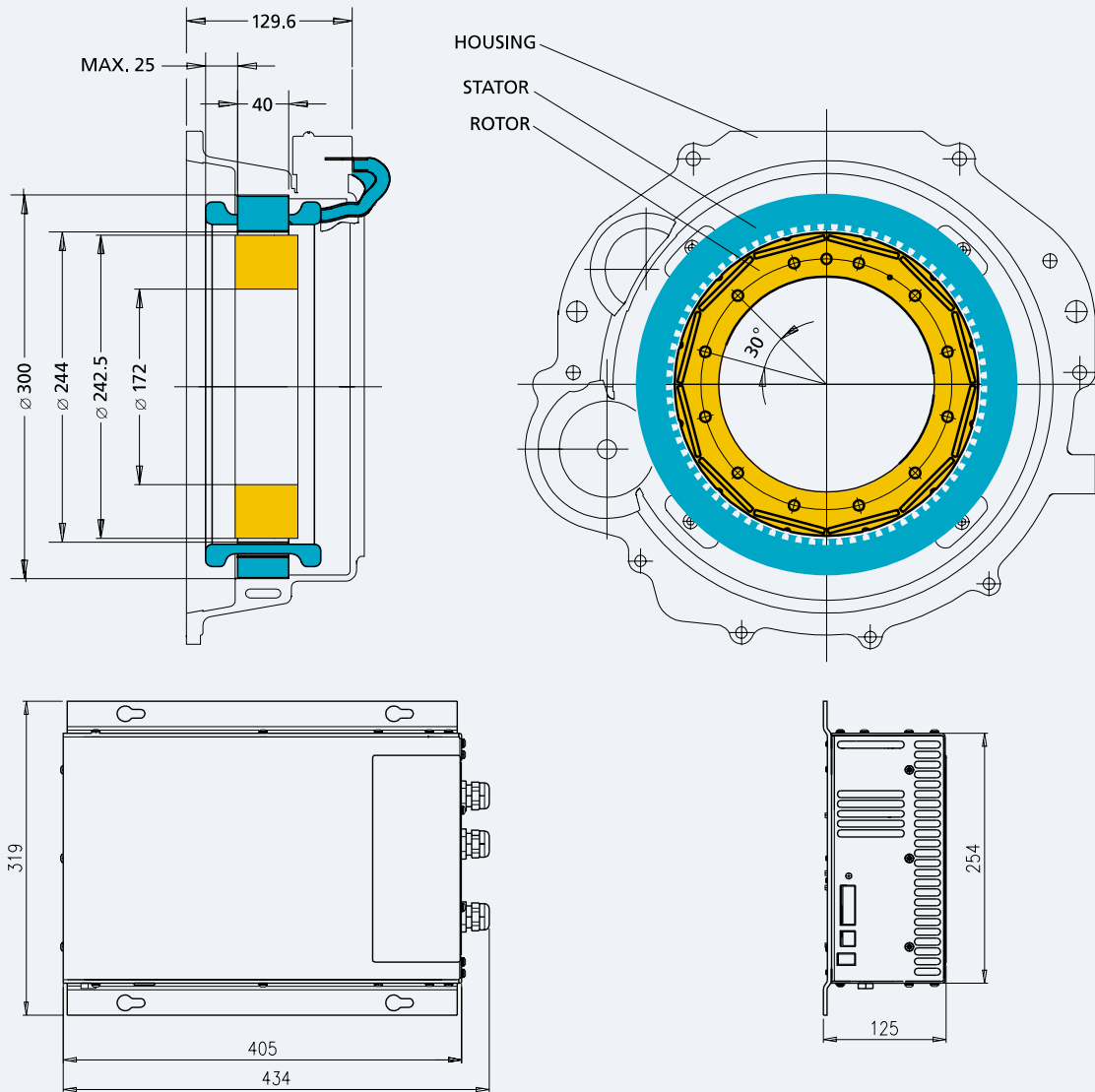

CHARACTERISTIC

- Output power
- Efficiency

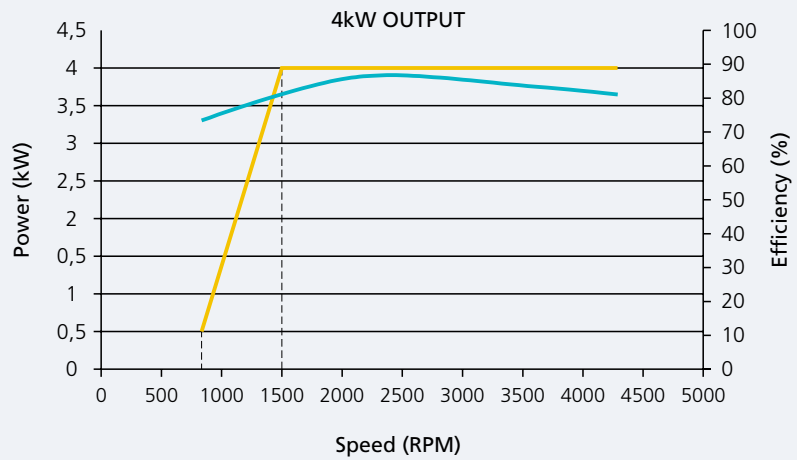

CONNECTION DIAGRAM

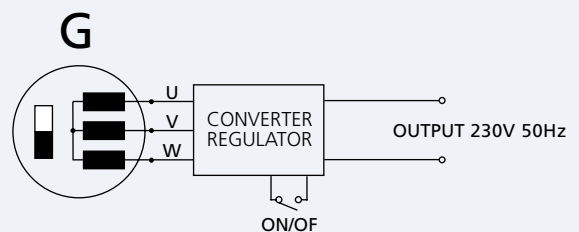

NOTE: For installation details see special instructions or contact us.

The integrated starter generator is an advanced electrical machine controlled by electronics and is intended for integration with internal combustion engines. It replaces the conventional starter motor and alternator, which are the two indispensable electric units on almost every engine.

This new integrated starter generator offers several new functions so the final users get the following operation modes from a single integrated starter generator:

- Starter mode for the main internal combustion engine
- DC generator mode for battery charging replacing the alternator
- Electric motor mode for electric propulsion
- Booster electric motor mode as an extra power to the IC engine for better acceleration

Engines equipped with this device will become especially attractive for operation on boats, special vehicles and stationary generator sets.

By assembly of this integrated starter generator through the mechanical couplings on main engine side as well as on the gearbox side, the drive system becomes of a hybrid kind that can expand its use into restrictive areas and in general offers a bigger comfort for the final users.

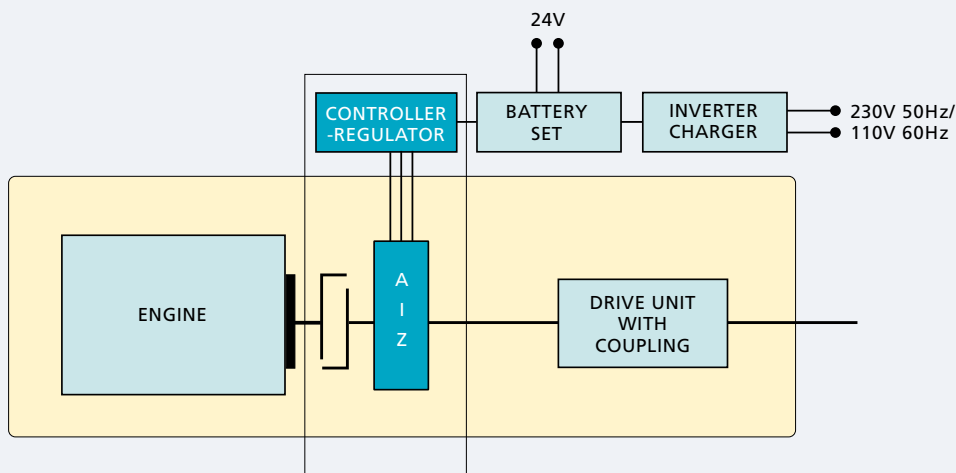

LAY OUT SAMPLE OF MARINE HYBRIDE PROPULSION SYSTEM

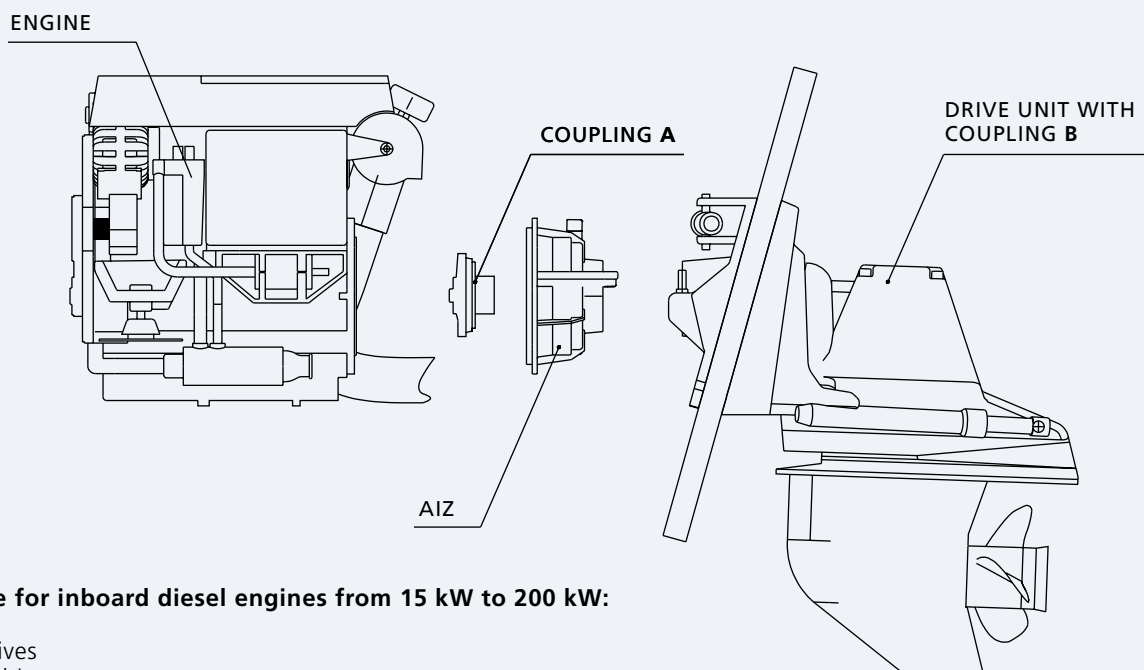

Suitable for inboard diesel engines from 15 kW to 200 kW:

- Sail drives
- Stern drives
- Inboard with shaft drive



FEATURES OF FLYWHEEL STARTER MOTOR GENERATOR

- Four operating modes (starter, generator, electric propulsion and booster)
- Maintenance free brushless solution
- High efficiency
- High specific power
- 28 V DC output
- Over current and over temperature protection
- Silent operation
- Compact design of electric motor which is integrated in the flywheel housing
- Eliminates the conventional alternator and starter motor
- Reduces outline dimensions of the engine
- Provides selectable charging voltage for wet or gel batteries
- No contactors are requested in electrical connections

The system substitutes some conventional elements of the engine. These are alternator, starter motor and flywheel elements. Usually assembly leads to a little prolongation of the engine but its width becomes narrower. The stator with windings needs to be installed in a modified flywheel housing which must include the cooling tubes for the coolant. The necessary modifications on the engine flywheel housing and the coupling to the rotor must be carefully redesigned in collaboration with both sides engineering.

DESIGN

Iskra's integrated starter motor generator is a three-phase brushless permanent magnet synchronous machine controlled by power electronics. The system consist of stator, rotor and a separate electronic controller which enables control over four different operational modes namely with functions of starter, generator, electric propulsion and booster.

Stator

The stator has a three-phase winding on a laminated pack. The optimized design and high fill factor of the winding provide improved efficiency, low noise operation and high output characteristics of the system. For nominal output power, adequate water-cooling must be provided through the flywheel housing cooling tubes.

Rotor

The rotor integrates high-energy rare earth permanent magnets and without any windings or electrical slip rings assures long life and maintenance free operation. It is normally fixed to the engine flywheel with 12 screws. Such assembly needs to be well mechanically balanced.

Electronic controller - regulator

The electronic controller is located in a separate box and integrates small signal electronics and power elements of the most advanced IGBT technology. In the small signal part of the electronics are flash microcontrollers which efficiently control the electric machine and at the same time provide remote control either through the pins on input connector or through the CAN buss connector. The power stage is assembled on a base plate in which the sea water resistant cooling tubes provide necessary heat dissipation. For convenience during electric installation the electronic controller box already carries a fuse, which is normally in + line with the batteries.

MAIN TECHNICAL DATA

| | |
|----------------------------------|---------------------------------|
| Nominal voltage | 24 V |
| Starter output power | 2 kW |
| Maximal torque | 180 Nm |
| DC generator output power | 5 kW continuous |
| Generator voltage | 28.1 or 28.8 V |
| Max output current | 200 A |
| Electric propulsion output power | 5 kW at 1000 rpm for 30 minutes |
| Booster output power | Up to 10 kW for 15 seconds |
| Stator weight | 8 kg |
| Rotor weight | 8 kg |
| Max. rotor speed | 4500 rpm |
| Electronic controller weight | 22 kg |
| Electronic controller dimensions | 562 x 316 x 192 mm |
| Max. liquid coolant temperature | 30° C |
| Min. coolant flow | 4 litre/min |

STARTER GENERATOR AND ELECTRONIC CONTROLLER DIMENSIONS

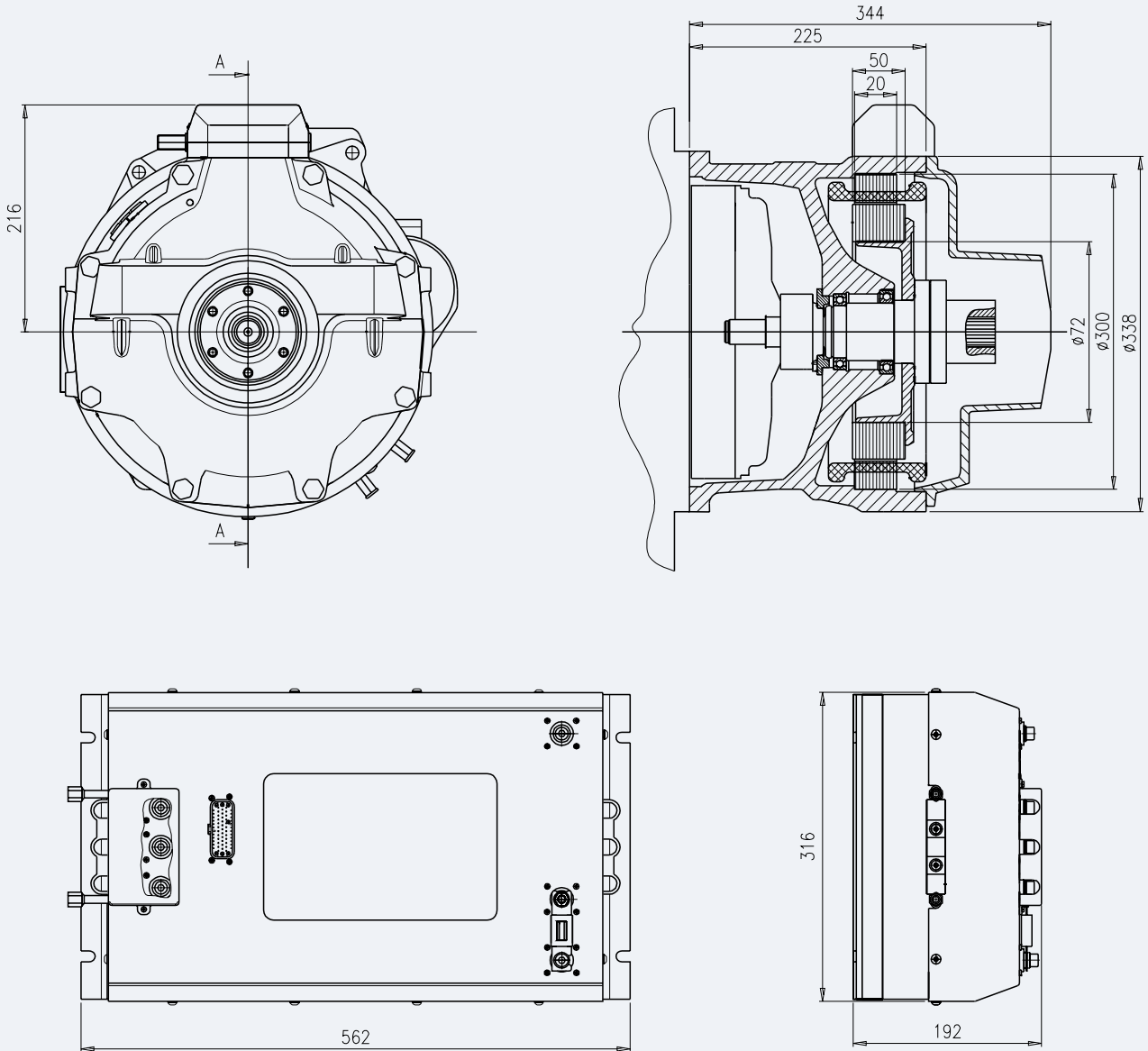

CONNECTOR DIAGRAM

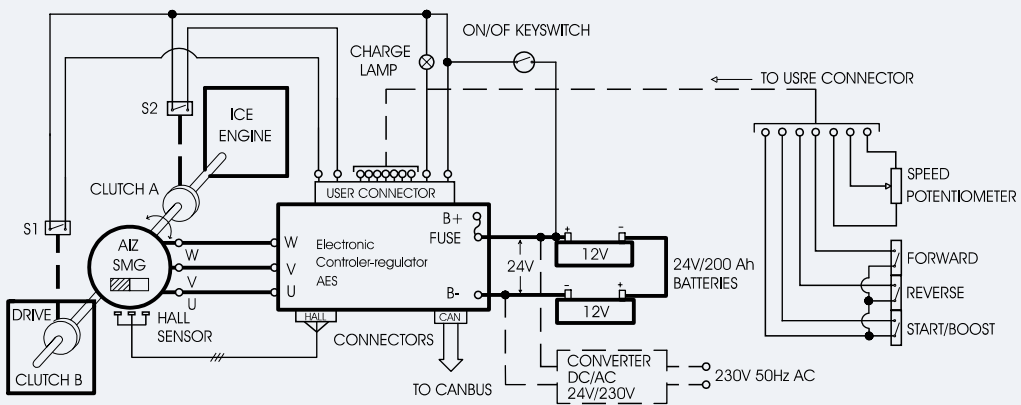

CHARACTERISTICS

A. Starter characteristics

- Power
- Speed

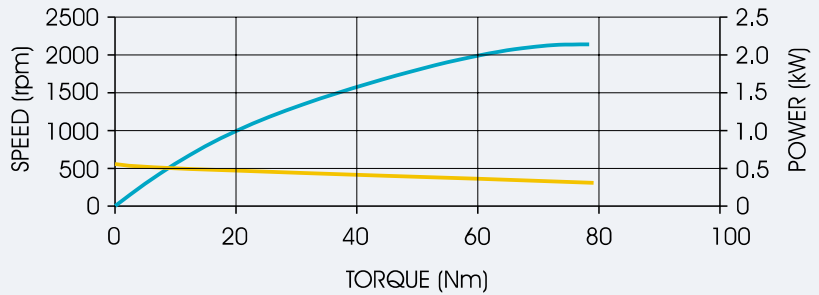

B. Generator characteristics

- Current
- Efficiency

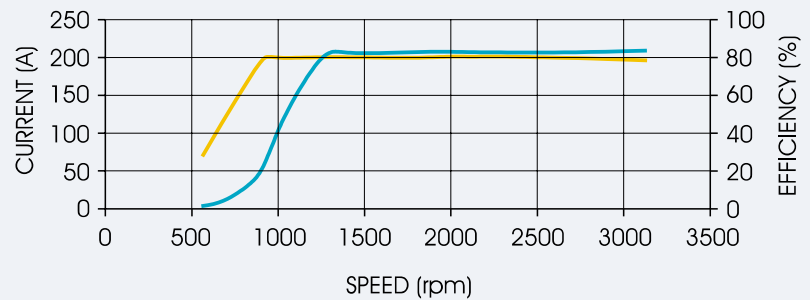

C. Electric propulsion characteristics

- Power
- Speed

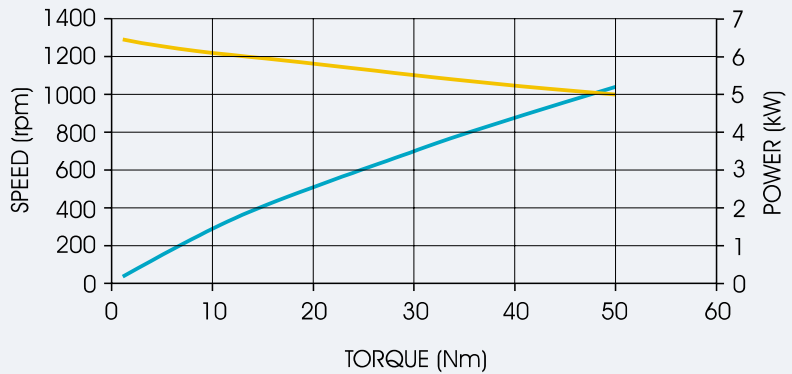

D. Booster characteristics

- Power
- Speed

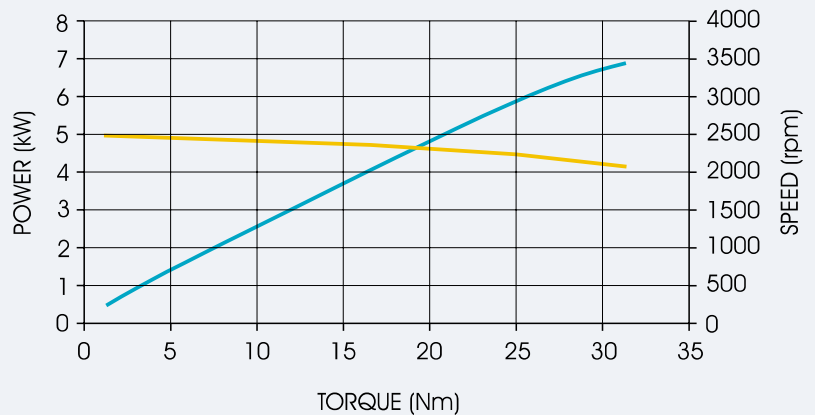

E. Batteries

The batteries represent the fuel tank of the electric motor system. It is very important to choose the batteries that, in size and capacity, suit to your requirements. Please note that you must use batteries that can be discharged by 75 - 80% on regular basis. They can be Wet, Gel or AGM type of lead batteries. DO NOT use starting batteries. They are not developed for deep discharge.

MODES OF OPERATION

All functions and operating modes are engaged and controlled with the electronic controller through input pins or CAN bus communications.

A. Starting mode

Coupling A must be engaged and coupling B disengaged for this mode of operation. The integrated starter generator will efficiently rotate the engine with cranking speed and by this provide about 2 kW power to start the engine. Direction of rotation can be adjusted to the rotation of IC engine. Upon release of the start function, the system will automatically switch to generator mode.

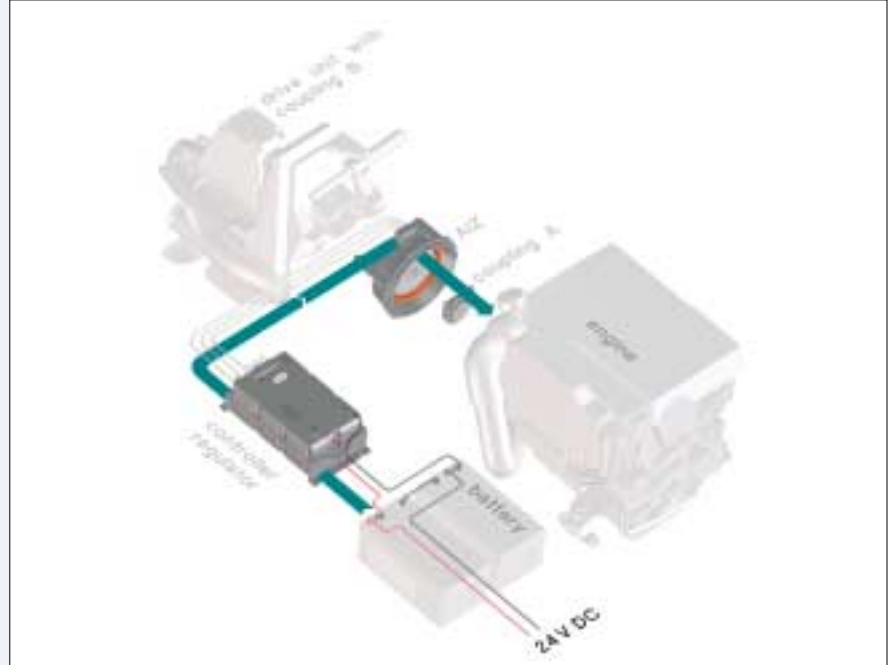

B. Generator mode

Coupling A must be engaged during this mode. Generator mode is engaged immediately after a start or a boost function has ended. Generator will provide 5 kW of continuous DC electric power through the electronic controller to the batteries and all the loads on the batteries. The charging voltage can be selected by pin condition on input connector and it can be accommodated to wet or gel cells with nominal voltage of 24 V.

Available is the option to connect standard inverters in parallel to the 24V batteries with 230 V 50 Hz or 110 V 60 Hz AC output in those applications that have loads intended for AC electricity like many domestic appliances. Obviously final users will enjoy such inverter operation when the main engine is running for longer periods of time or when stopped for a limited time depending on battery capacity.

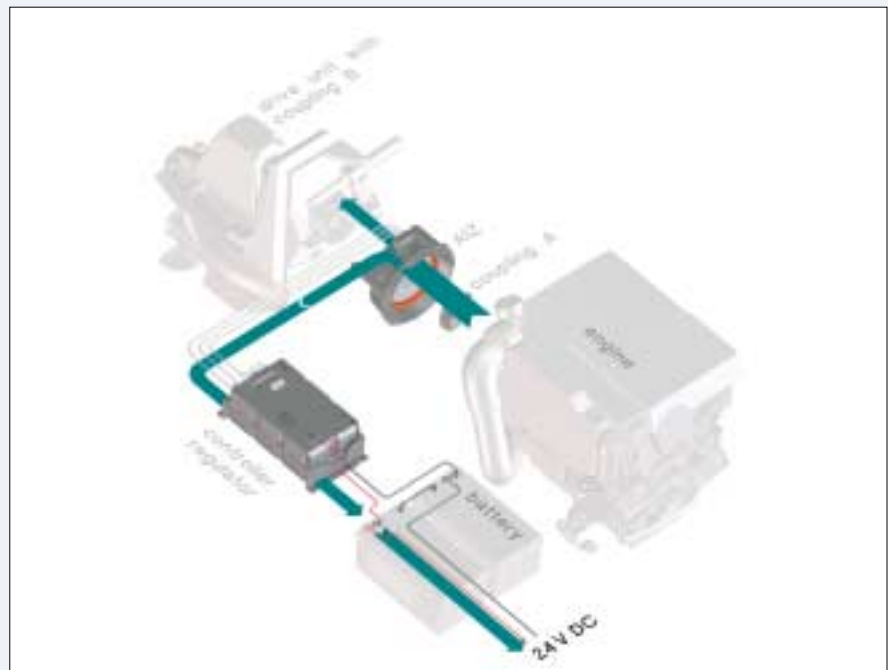

C. Electric propulsion mode

Coupling A must be disengaged and coupling B must be engaged in order to engage this mode of operation. Main IC engine will be stopped during this mode and therefore the user will enjoy a very quiet drive.

The integrated starter motor generator will provide 5 kW of output power as electrical propulsion for a limited time dependent on batteries capacity. With a 24 V 200 Ah fully charged battery set it is expected the system could operate for about half an hour.

Speed of rotation can be controlled by means of connecting a joystick-potentiometer to the pins on input connector or can be commanded through the CAN buss.

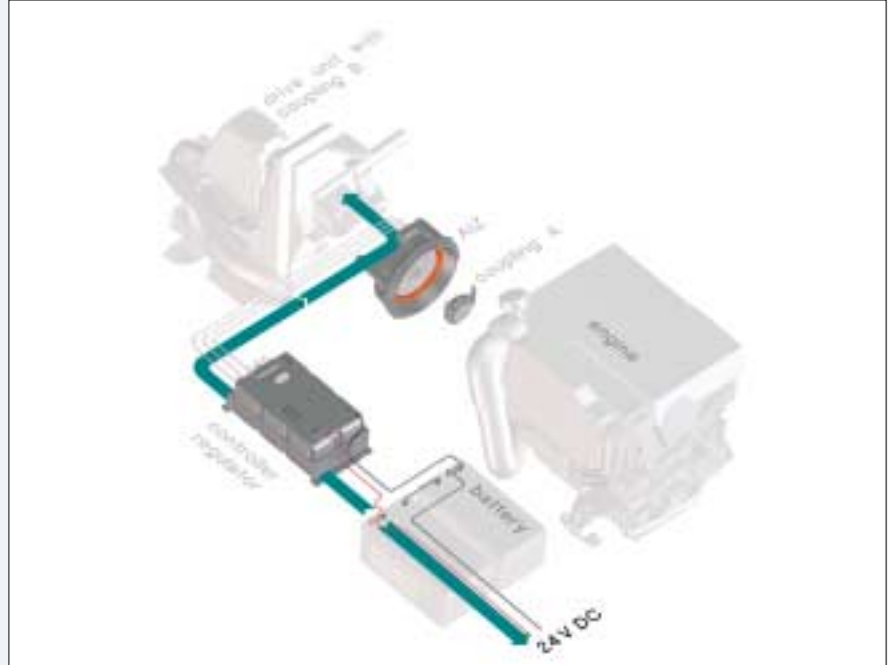

D. Booster mode

During this mode both couplings A and B need to be engaged. The integrated starter generator operates in this mode as an electric motor in parallel with the main combustion engine therefore contributing about 10 kW extra power in addition to main engine power. The boost effect is more perceivable at low speeds of the main engine and will practically become negligible for speeds over 2500 rpm.

Booster mode is limited to 15 seconds of operating time by software in the controller in order to prevent overheating of system components. Several boost cycles can be engaged subsequently it being overheat protection will cut off this function. At this point the system will need to cool down before a new cycle can be engaged again.

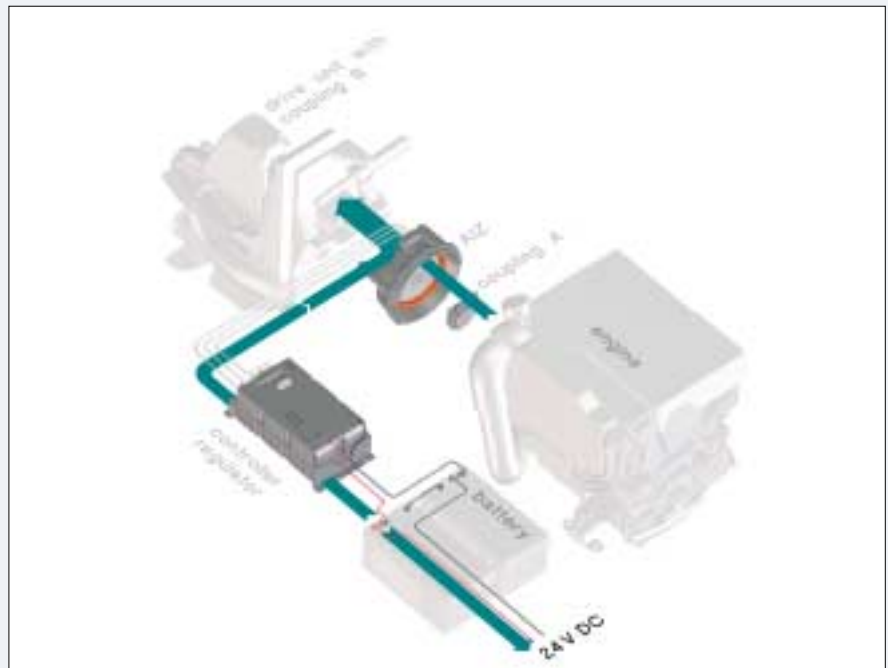

Iskra Avtoelektrika, d. d.

Polje 15, Slovenia
5290 Šempeter pri Gorici
Tel.: +386 5 33 93 000
Fax: +386 5 33 93 801
E-mail: info@iskra-ae.com
www.iskra-ae.com

BELARUS

Iskra o. o. o.
Ul. Dombrovskogo 69
230002 Grodno
Tel.: +375 152 487 484
Tel/Fax: +375 152 487 485
E-mail: iskra@mail.grodno.by

BOSNIA AND HERZEGOVINA

Iskra AE Komponente, d. o. o.
Nemanjina 35
78250 Laktaši
Tel.: +387 51 53 07 85
Fax: +387 51 53 53 15
E-mail: iskra-ae@inecco.net

BRAZIL

Iskra do Brasil Ltda.
Rua Testa n. 81 -
Jardim Sao Sebastiao
Jaguariuna - (SP)
CEP 13820-000
Tel.: +55 19 3837 2363
Fax: +55 19 3837 3185
E-mail: uros.kravos@iskra-ae.com
www.iskra-ae.com.br

CHINA

Iskra Suzhou Autoelectric Co., Ltd.
Wenzhou Industrial Zone Shuangfeng
Taicang, Jiangsu Province
Tel: +86 512 8160 6888
Fax: +86 512 8160 7799
E-mail: iskrasuzhou@iskra-ae.com
www.iskra-ae.com.cn

Changchun Fawer
Iskra Automotive Electrical Co., Ltd.
No. 2258 Pudong Road
Changchun Economic
Technology Development Zone
Changchun, Jilin Province
Tel.: +86 431 461 5016
Fax: +86 431 461 5017
E-mail: zhj_fa@faw.com.cn

FRANCE

Iskra Autoelectrique S.A.S.
ZA du Chapeau Rouge
56000 Vannes
Tel.: +33 2 97 45 59 90
Fax: +33 2 97 45 59 99
E-mail: iskra@iskra-ae.fr
www.iskra-ae.fr

GERMANY

Iskra Deutschland GmbH
Danziger Strasse 1
71691 Freiberg am Neckar
Tel.: +49 7141 702 69 0
Fax: +49 7141 702 69 33
E-mail: info@iskra-ae.de
www.iskra-ae.de

GREAT BRITAIN

Iskra UK Ltd.
Redlands
Ullswater Crescent, Coulsdon
Surrey CR5 2HT
Tel.: +44 208 668 7141
Fax: +44 208 668 3108
E-mail: sales@iskra-agency.co.uk
www.iskra-ae.co.uk

IRAN

Iskra Autoelectric Iran JVC
No.28, East Mirdamad Avenue
Tehran 15469-34311
Tel.: +98 21 2 226 237 1 - 4
Fax: +98 21 2 226 237 6
E-mail: info@iskra-iran.com

ITALY

Iskra Autel S. r. l.
Via G. Cantore, 2
34170 Gorizia
Tel.: +39 0481 536 800
Fax: +39 0481 536 810
E-mail: info@iskra-autel.it
www.iskra-autel.it

RUSSIA

Iskra Avtoelektrika
Representative Office
Storozhevaya str., 4,
building 1 office 123
111020 Moscow
Tel.: +7 095 726 93 94
Fax: +7 095 225 84 06
E-mail: info@iskra-ae.ru
www.iskra-ae.ru

Pramo Iskra o.o.o.
Zubcovskoe shosse 21
172387 Rzhev, Tverskaya obl.
Representative office in Moscow
Elektrozavodskaya str. 21
107023 Moscow
Tel. / Fax: +7 495 995 2512
E-mail: iskra@pramo.ru

SPAIN

Iskra Autoelectrique Spain S.A.
Calle Llobatona No. 6-D
08840 Viladecans
Tel.: +34 93 647 40 83
Fax: +34 93 647 40 84
E-mail: iskra@iskra-ae.es
www.iskra-ae.fr/esp/

USA

Iskra AE Inc.
4814 American Road
Rockford, IL 61109
Tel.: +1 800 474 1996
Tel.: +1 815 874 4022
Fax.: +1 815 874 4024
E-mail: iskra@iskraae.com
www.iskraae.com